

INSTRUCTIONS FOR USE – LMA Unique PreCurved™ & LMA Unique PreCurved™ Cuff Pilot™

CAUTION: Federal (USA) law restricts this device to sale by or on the order of a physician.

WARNING: LMA Unique PreCurved™ and LMA Unique PreCurved™ Cuff Pilot™ are supplied sterile for single use only, should be used straight from the pack and should be discarded after use. They must not be re-used. Reuse may cause cross infection and reduce product reliability and functionality.

WARNING: Re-processing of LMA Unique PreCurved™ and LMA Unique PreCurved™ Cuff Pilot™ intended for single use only may result in degraded performance or loss of functionality. Re-use of single use only products may result in exposure to viral, bacterial, fungal, or prionic pathogens. Validated cleaning and sterilisation methods and instructions for reprocessing to original specifications are not available for these products. LMA Unique PreCurved™ and LMA Unique PreCurved™ Cuff Pilot™ are not designed to be cleaned, disinfected, or re-sterilised.

GENERAL INFORMATION:

Unless otherwise stated, the reference to “device” stated on this IFU applies to both versions of LMA Unique PreCurved™ and LMA Unique PreCurved™ Cuff Pilot™.

The devices are only for use by medical professionals trained in airway management.

DEVICE DESCRIPTION:

Both the LMA Unique PreCurved™ and LMA Unique PreCurved™ Cuff Pilot™ are not made with natural rubber latex and phthalates. They are supplied sterile (sterilised by Ethylene Oxide) for single use only.

LMA Unique PreCurved™ and LMA Unique PreCurved™ Cuff Pilot™ provide easy insertion without the need for digital or introducer tool guidance.

LMA Unique PreCurved™ and LMA Unique PreCurved™ Cuff Pilot™ have three main components: airway tube, cuff and inflation system.

The inflation system of LMA Unique PreCurved™ consists of an Inflation Line with Pilot Balloon and Check Valve for cuff inflation and deflation. The Pilot Balloon provides a rough indication of the pressure within the cuff and the Check Valve prevents leakage of air and maintains the pressure in cuff.

The inflation system of LMA Unique PreCurved™ Cuff Pilot™ consists of an Inflation Line with a Cuff Pilot™. The Cuff Pilot™ enables constant visualisation of pressure inside the mask cuff. It replaces the standard pilot balloon and is to be used in the same way for cuff inflation and deflation.

LMA Unique PreCurved™ is MR conditional. Refer to MRI information section prior to using the device in MRI environment.

LMA Unique PreCurved™ Cuff Pilot™ is MR Safe. The term ‘MR Safe’ means that it poses no known hazards in all MR environments.

Figure 1: The LMA Unique PreCurved™ components

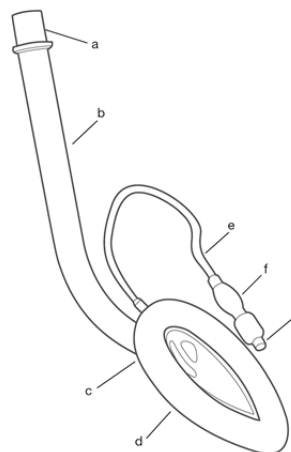

LMA Unique PreCurved™ components (Figure 1):

- a) Connector
- b) Airway Tube
- c) Backplate
- d) Cuff
- e) Inflation Line
- f) Pilot Balloon
- g) Check Valve

Figure 2: LMA Unique PreCurved™ Cuff Pilot™ components

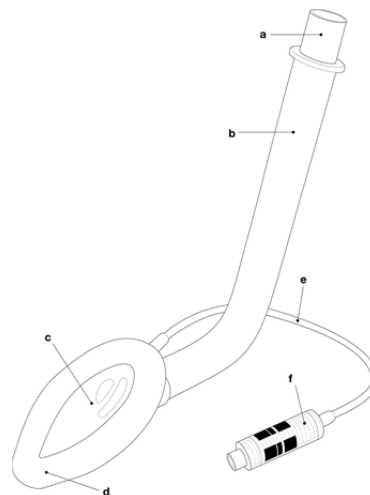

LMA Unique PreCurved™ Cuff Pilot™ components (Figure 2):

- a) Connector
- b) Airway Tube
- c) Backplate
- d) Cuff
- e) Inflation Line
- f) Cuff Pilot™

Table 1: Specification for the device

	Device Size						
	1	1.5	2	2.5	3	4	5
Patient Weight (kg)	Up to 5	5-10	10-20	20-30	30-50	50-70	70-100
Airway Connector	15 mm male (ISO 5356-1)						
Inflation Valve	Luer cone (ISO 594-1)						
Internal Volume of ventilator pathway (ml)	4	5	8	10	19	19	27
Pressure drop (mm H ₂ O)	< 22 at 15 l/min	< 10 at 15 l/min	< 20 at 30 l/min	< 10 at 30 l/min	< 16 at 60 l/min	< 16 at 60 l/min	< 12 at 60 l/min
Min. interidental gap (mm)	16	18	21	24	29	30	34
Normal length of the internal ventilatory pathway (cm)	12.0	13.5	15.5	16.5	22.0	22.0	24.0

A summary of the methods, materials, data and results of clinical studies that validate the requirements of this international standard is available on request, if applicable.

Correct Position of the device in relation to anatomical landmarks

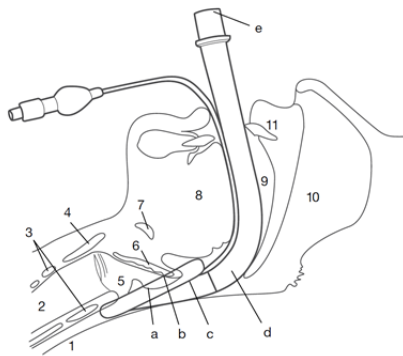

Table 2: Description of anatomical landmarks

Anatomical Landmarks	
1 - Esophagus	7 - Hyoid bone
2 - Trachea	8 - Tongue
3 - Cricoid cartilage	9 - Buccal cavity
4 - Thyroid cartilage	10 - Nasopharynx
5 - Laryngeal inlet	11 - Incisors
6 - Epiglottis	

Table 3: Description of the device parts

a - Patient end	d - Ventilatory pathway
b - Ventilatory opening	e - External end connector
c - Sealing mechanism	

INDICATION FOR USE:

The LMA Unique PreCurved™ and LMA Unique PreCurved™ Cuff Pilot™ are indicated for use in achieving and maintaining control of the airway during routine anaesthetic procedures in fasted patients using either spontaneous or Positive Pressure Ventilation (PPV).

They are also indicated for securing the immediate airway in known or unexpected difficult airway situations.

They are suited for use in elective surgical procedures where tracheal intubation is not necessary.

They may be used to establish an immediate, clear airway during cardiopulmonary resuscitation (CPR) in the profoundly unconscious patient with absent glossopharyngeal and laryngeal reflexes requiring artificial ventilation. In these cases, the devices should be used only when tracheal intubation is not possible.

RISK-BENEFIT INFORMATION:

When used in the profoundly unresponsive patient in need of resuscitation or in a difficult airway patient on an emergency pathway (i.e., “cannot intubate, cannot ventilate”), the risk of regurgitation and aspiration must be weighed against the potential benefit of establishing an airway.

CONTRAINDICATIONS:

Due to the potential risk of regurgitation and aspiration, do not use the device as a substitute for an endotracheal tube in the following elective or difficult airway patients on a non-emergency pathway:

1. Patients who have not fasted, including patients whose fasting cannot be confirmed.
2. Patients who are morbidly obese, more than 14 weeks pregnant or emergency and resuscitation situations or any condition associated with delayed gastric emptying, or using opiate medication prior to fasting.
3. Patients with inadequate mouth opening to permit insertion.

The device is also contraindicated in:

1. Patients with fixed decreased pulmonary compliance, or peak insufflation pressure anticipated to exceed 20 cm H₂O, because the device forms a low-pressure seal (approximately 20 cm H₂O) around the larynx.
2. Adult patients who are unable to understand instructions or cannot adequately answer questions regarding their medical history, since such patients may be contraindicated for the device.
3. The device should not be used in the resuscitation or emergency situation in patients who are not profoundly unconscious and who may resist device insertion.

ADVERSE EFFECTS:

There are reported adverse reactions associated with the use of laryngeal mask airways. Standard textbooks and published literature should be consulted for specific information.

WARNINGS:

1. To avoid trauma, excessive force must be avoided at all times.
2. Do not use if the device is damaged or its unit packaging is damaged or opened.
3. When using the device in special environmental conditions, such as enriched oxygen, ensure that all necessary preparation and precautions have been taken, especially with regard to fire hazards and prevention. The device may be flammable in the presence of lasers and electrocautery equipment.
4. It is most important that pre-use checks are carried out on the device prior to use, in order to establish whether it is safe for use. Failure of any one test indicates the device should not be used.
5. Do not immerse or soak the device in liquid prior to use.
6. When applying lubricant avoid blockage of the airway aperture with the lubricant.
7. Never overinflate the cuff over 60cm H₂O. Excessive intra-cuff pressure can result in malposition and pharyngo-laryngeal morbidity, including sore throat, dysphagia and nerve injury.
8. A water-soluble lubricant, such as K-Y Jelly®, should be used. Do not use silicone-based lubricants as they degrade the device components. Lubricants containing Lidocaine are not recommended for use with the device. Lidocaine can delay the return of the patient’s protective reflexes expected prior to removal of the device, may possibly provoke an allergic reaction, or may affect the surrounding structures, including the vocal cords.
9. The device does not prevent regurgitation or aspiration. Its use in anaesthetised patients should be restricted to fasting patients. A number of conditions predispose to regurgitation under anaesthesia. Do not use the devices without taking appropriate precautions to ensure the stomach is empty.
10. Diffusion of nitrous oxide, oxygen, or air may increase or decrease cuff volume and pressure. In order to ensure that cuff pressures do not become excessive, cuff pressure should be measured regularly during a case with a cuff pressure monitor.
11. Refer to MRI information section prior to using the devices in MRI environment.

CAUTIONS:

1. Laryngeal spasm may occur if the patient becomes too lightly anaesthetized during surgical stimulation or if bronchial secretions irritate the vocal cords during emergence from anaesthesia. If laryngeal spasm occurs, treat the cause. Only remove the device when airway protective reflexes are fully competent.
2. Do not pull or use undue force when handling the inflation line or try to remove the device from patient by the inflation line as it may detach from the cuff spigot.
3. Only use a syringe with standard luer taper tip for inflation or deflation.
4. Only use with the recommended manoeuvres described in the instructions for use.
5. If airway problems persist or ventilation is inadequate, the device should be removed and an airway established by some other means.

6. Careful handling is essential. Avoid contact with sharp or pointed objects at all times to prevent tearing or perforation of the device. Do not insert the device unless the cuffs are fully deflated as described in the instructions for insertion.
7. Gloves should be worn during preparation and insertion to minimize contamination of the airway.
8. Used device shall follow a handling and elimination process for bio-hazard products, in accordance with all local and national regulations.
9. Store the device in a dark cool environment, avoiding direct sunlight or extremes of temperatures.
10. Ensure all removable denture work is removed before inserting the device.
11. An unreliable or obstructed airway may result in cases where the device has been incorrectly inserted.

PREPARATION FOR USE:

Choose the correct size of device. Refer to Table 1 for patient weight and size information.

Keep a clearly marked syringe for inflation and deflation of the cuff.

PRE-USE CHECKS:

Warning: It is most important that pre-use checks are carried out on the device prior to use, in order to establish whether they are safe for use.

Warning: Failure of any one test indicates the device should not be used.

These tests should be carried out as follows:

1. **Examine the interior of the airway tube** to ensure it is free from blockage or loose particles. Examine the tube throughout its length. Should any cuts or indentations be found, discard the device.
2. **Holding at each end flex the airway tube** to increase its curvature up to but not beyond 180°. Should the tube kink during this procedure, discard the device.
3. **Deflate the cuff fully.**

For LMA Unique™ PreCurved™

Re-inflate the device with a volume of air 50% greater than the maximum inflation value for each size.

Table 4: Test cuff over-inflation volumes

	Device Size						
	1	1.5	2	2.5	3	4	5
Over-inflation cuff volumes (ml)	6	10	15	21	30	45	60

Examine the cuff for leaks, herniations and uneven bulging. If any indications of these problems exist, discard the device. A herniating mask may cause obstruction during use. Then deflate the mask again. While the device remains 50% over-inflated, examine the inflation pilot balloon. The balloon shape should be elliptical, not spherical.

For LMA Unique PreCurved™ Cuff Pilot™

Re-inflate the device to Red Zone of Cuff Pilot™ (Fig 13) with a volume of air > 70cmH₂O.

Examine the cuff for leaks, herniations and uneven bulging. If any indications of these problems exist, discard the device. A herniating mask may cause obstruction during use. Then, deflate the mask again.

4. **Examine the airway connector.** It should fit securely into the airway tube and it should not be possible using reasonable force, to remove. Do not use excessive force or twist the connector as this may break the seal. If the connector is loose, discard the device to avoid the risk of accidental disconnection during use.
5. **Discoloration.** Discoloration affects visibility of fluid in the airway tube.
6. Gently pull the inflation line to ensure it is securely attached to both the cuff and balloon.
7. **Examine the aperture in the mask.** Gently probe the two flexible bars traversing the mask aperture to ensure they are not broken or otherwise damaged. If the aperture bars are not intact, the epiglottis may obstruct the airway. Do not use if the aperture bar is damaged.

PRE-INSERTION PREPARATION:

Deflate completely using the LMA™ Cuff Deflator in order to create the stiff thin leading edge necessary to wedge the tip behind the cricoid cartilage. The cuff should fold back away from the aperture bars. Lubricate the back of the cuff thoroughly just before insertion. Do not lubricate the front as this may result in blockage of aperture bar or aspiration of lubricant.

Warning: A water-soluble lubricant, such as K-Y Jelly®, should be used. Do not use silicone-based lubricants as they degrade the device components. Lubricants containing Lidocaine are not recommended for use with the device. Lidocaine can delay the return of the patient's protective reflexes expected prior to removal of the device, may possibly provoke an allergic reaction, or may affect the surrounding structures, including the vocal cords.

Caution: Ensure all removable denture work is removed before inserting the device.

INSERTION:

Caution: Gloves should be worn during preparation and insertion to minimize contamination of the airway.

Caution: The patency of this device should be reconfirmed after any change in the patient's head or neck position.

1. Anaesthesia must be deep enough to permit insertion.

Do not try to insert immediately following barbiturate induction, unless a relaxant drug has been given.

2. Hold the LMA Unique PreCurved™ in position. (Fig. 3)

Position the head and neck as for normal tracheal intubation.

Place the head in the neutral or slight "sniffing" position (Sniffing = extension of head + flexion of neck) by pushing the head from behind with one hand while inserting the mask into the mouth with the other hand. (Fig. 4)

3. Press the distal tip against the inner aspect of the upper teeth or gums. (Fig. 5)

4. Slide inwards using a slightly diagonal approach (direct the tip away from the mid-line). (Fig. 6)

5. Continue to slide inwards rotating the hand in a circular motion so that the device follows the curvature behind the tongue. (Fig.7)

6. Resistance should be felt when the distal end of the device meets final position in the lower pharynx. The device is now fully inserted. (Fig. 8)

7. Check that the black dotted line on the tube faces the upper lip.

Now immediately inflate the cuff **without holding the tube.** (Fig.-9)

Do this **BEFORE** connection to the gas supply. This will permit the device to position itself correctly. Inflate the cuff with sufficient air to obtain a low pressure seal. Refer to Table 5 for inflation information. During cuff inflation, do not hold the tube as this prevents the device from settling into its correct location.

Warning: NEVER OVERINFLATE THE CUFF.

Table 5: Inflation Information

Product	Recommended	Device Size						
		1	1.5	2	2.5	3	4	5
LMA Unique PreCurved™	Maximum Cuff inflation volume (ml/60cmH ₂ O)	4	7	10	14	20	30	40
LMA Unique PreCurved™ Cuff Pilot™	Intracuff pressure (cmH ₂ O)	60	60	60	60	60	60	60

8. Connect to a gas supply, holding the tube, to prevent displacement. **Gently** inflate the lungs to confirm correct placement. Insert a roll of gauze as bite-block (ensuring adequate thickness), and tape the device into place, ensuring that the proximal end of the airway tube is pointing caudally (Fig.10). When correctly placed, the tube should be pressed back into the palate and posterior pharyngeal wall. When using the device, it is important to remember to insert a bite block at the end of the procedure.

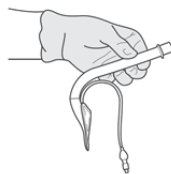

Figure 3: Hold the LMA Unique PreCurved™ in position



Figure 4: Position the head and neck as for normal tracheal intubation.



Figure 5: Press the tip of the mask against the hard palate



Figure 6: Press the cuff further into the mouth, maintaining pressure against the palate.

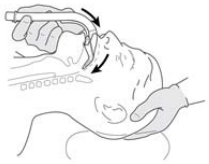

Figure 7: Swing the device inward with circular motion, pressing against the contours of the hard and the soft palate



Figure 8: Advance the device into the lower pharynx until resistance is felt.

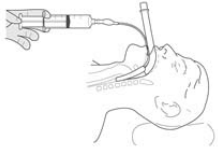

Figure 9: Inflate the cuff without holding the tube



Figure 10: Insert a roll of gauze as bite-block, and tape the device into place, ensuring that the proximal end of the airway tube is pointing caudally.

Inflation System of LMA Unique PreCurved™ Cuff Pilot™:

1. The LMA Unique PreCurved™ Cuff Pilot™ has a cuff pilot valve, which constantly monitors the intracuff pressure of the mask while it is inserted in the patient's airway. There are three pressure zones on the Cuff Pilot Valve – Yellow, Green and Red. The position of the black line on the bellows indicates the pressure within the cuff.
2. The Green Zone designates optimal pressure of the cuff, between 40 - 60 cmH₂O. Air is introduced into the cuff until the black line is within this zone and a seal has been obtained.



Figure 11: Cuff Pilot Valve in Green Zone

3. The Yellow Zone indicates a pressure of less than 40cmH₂O. A seal may be obtained in the Yellow Zone; however, movement of the black line on the bellows into the Yellow Zone during the procedure may indicate a possible decrease in pressure or under-inflation.



Figure 12: Cuff Pilot Valve in Yellow Zone

4. The Red Zone indicates a pressure of more than 70cmH₂O. This indicates a possible increase in pressure or over-inflation. It is recommended that the pressure be released until the black bellows line is back in the Green Zone.



Figure 13: Cuff Pilot Valve in Red Zone

Warning: NEVER OVERINFLATE THE CUFF.

MAINTAINING THE AIRWAY:

1. Obstruction can occur if the device becomes dislodged or is incorrectly inserted. The epiglottis may be pushed down with poor insertion technique. Check by auscultation of the neck and correct by re-insertion or elevation of the epiglottis using a laryngoscope.
2. Malposition of mask tip into the glottis may mimic laryngospasm and/or bronchospasm.
3. Avoid moving the device about in the pharynx when the patient is at a light plane of anaesthesia.
4. Keep the bite-block in place until the device is removed.
5. Do not deflate the cuff until reflexes have fully returned.
6. Air may be withdrawn from the cuff during anaesthesia to maintain a constant intra-cuff pressure (always less than 60cm H₂O).

REMOVAL:

1. **The device, together with the recommended bite-block, should be left in place until the return of consciousness.** Oxygen should be administered using a "T" piece system and standard monitoring should be in place. Before attempting to remove or deflate the device, **it is essential to leave the patient completely undisturbed until protective reflexes have fully returned. Do not remove the device until the patient can open the mouth on command.**
2. Look for the onset of swallowing which indicates reflexes are almost restored. It is usually unnecessary to perform suction because the correctly used device protects the larynx from oral secretions. Patients will swallow secretions on removal. **Suction equipment should however be available at all times.**
3. Deflate the cuff completely just prior to removal, although partial deflation can be recommended in order to assist in the removal of secretions.

USE WITH MAGNETIC RESONANCE IMAGING (MRI):

For LMA Unique PreCurved™



The LMA Unique PreCurved™ is MR Conditional.

Non-clinical testing demonstrated that this product is MR Conditional. A patient with LMA Unique PreCurved™ can be scanned safely immediately after placement under the following conditions:

- Before the patient enters the MRI system room, the airway must be fixed properly in place with adhesive tape, cloth tape or other appropriate means to prevent movement or dislodgement.
- Static magnetic field of 3-Tesla or less
- Maximum spatial gradient magnetic field of 720-Gauss/cm or less
- Maximum MR system reported, whole body averaged specific absorption rate (SAR) of 4-W/kg (First Level Controlled Mode of operation for the MR system) for 15 minutes of scanning (i.e., per pulse sequence)

MRI-Related Heating

Under the scan conditions defined above, the LMA Unique PreCurved™ is expected to produce a maximum temperature rise of 2.5°C after 15 minutes of continuous scanning.

Artifact Information





















The maximum artifact size as seen on a gradient echo pulse sequence and a 3-Tesla MR system extends approximately 50 mm relative to the size and shape of the LMA Unique PreCurved™.

For LMA Unique PreCurved™ Cuff Pilot™



The LMA Unique PreCurved™ Cuff Pilot™ is MR Safe (i.e., an item that poses no known hazards in all MR environments).

SYMBOL DEFINITION:

	Manufacturer
	Consult IFU on this website: www.LMACO.com
	Air inflation volume / Intra-cuff pressure
	Patient weight
	Read Instructions before use
	Not made with natural rubber latex
	Fragile, handle with care
	Keep away from sunlight
	Keep dry
	This way up
	Product Code
	Lot Number
	CE Mark
	Do not Re-use
	Do not Re-sterilise
	This product not made with phthalates
	Sterilised by Ethylene Oxide
	Use By
	Do not use if package is damaged
	MR Conditional
	MR Safe

Copyright © 2015 Teleflex Incorporated.

All rights reserved. No part of this publication may be reproduced, stored in a retrieval system or transmitted in any form or by any means electrical, mechanical, photocopying, recording or otherwise, without the prior permission of the publisher.

LMA, LMA Better by Design, LMA Unique PreCurved, Cuff Pilot and Teleflex are trademarks or registered trademarks of Teleflex Incorporated or its affiliates.

The information given in this document is correct at the time of going to press. The manufacturer reserves the right to improve or modify the products without prior notification.

Manufacturer's Warranty:

The LMA Unique PreCurved™ and LMA Unique PreCurved™ Cuff Pilot™ are designed for single use and warranted against manufacturing defects at the time of delivery.

Warranty is applicable only if purchased from an authorized distributor. TELEFLEX MEDICAL DISCLAIMS ALL OTHER WARRANTIES, WHETHER EXPRESS OR IMPLIED, INCLUDING, WITHOUT LIMITATION, THE WARRANTIES OF MERCHANTABILITY OR FITNESS FOR APARTICULAR PURPOSE.



Teleflex Medical
IDA Business and Technology Park
Dublin Road, Athlone, Co Westmeath, Ireland

Contact Information in USA:
Teleflex Medical
2917 Weck Drive, Research Triangle Park, NC 27709 USA
International: (919)544-8000
USA: (866) 246-6990



www.LMACO.com

Issue: PBK-2100-000 Rev D UK